

ISL70003SEH iSim:PE Model

Introduction

The ISL70003SEH is a radiation and SEE hardened synchronous buck regulator capable of operating over an input voltage range of 3.0V to 13.2V. The ISL70003SEH uses voltage mode control architecture with feed-forward and switches at a selectable frequency of 500kHz or 300kHz. Loop compensation is externally adjustable to allow for an optimum balance between stability and output dynamic performance. With integrated MOSFETs and class leading radiation performance, this highly efficient single chip power solution is an ideal choice in many space applications.

The iSim:PE model for the ISL70003SEH was developed to help system designers evaluate the operation of this IC prior to or in conjunction with proto-typing a system design. This model accurately simulates typical performance characteristics such as loop analysis, transient analysis, start-up and steady state analysis at room temperature (+25 °C).

Reference Documents

- ISL70003SEH Data Sheet; [FN8604](#)
- ISL70003SEH SMD [5962-14203](#)

License Statement

The information in this macro-model is protected under the United States copyright laws. Intersil Corporation hereby grants users of this macro-model hereto referred to as "Licensee", a nonexclusive, nontransferable license to use this model as long as the Licensee abides by the terms of this agreement. Before using this macro-model, the Licensee should read this

license. If the Licensee does not accept these terms, permission to use the model is not granted.

The Licensee may not sell, loan, rent, or license the macro-model, in whole, in part, or in modified form, to anyone outside the Licensee's company. The Licensee may modify the macro-model to suit his/her specific applications, and the Licensee may make copies of this macro-model for use within their company only.

This macro-model is provided "AS IS, WHERE IS, AND WITH NO WARRANTY OF ANY KIND EITHER EXPRESSED OR IMPLIED, INCLUDING, BUT NOT LIMITED TO, ANY IMPLIED WARRANTIES OF MERCHANTABILITY AND FITNESS FOR A PARTICULAR PURPOSE."

In no event will Intersil be liable for special, collateral, incidental, or consequential damages in connection with or arising out of the use of this macro-model. Intersil reserves the right to make changes to the product and the macro-model without prior notice.

Schematic File

The schematic file: **ISL70003SEH.sxsch** is the main application schematic to be used in the iSim:PE simulator. The schematic mimics the evaluation board and is designed for 12V input to 3.3V output conversion, see Figure 1. The simulation profile is set up to run an AC and 3A load transient test. Figure 2 through 13 show a comparison of the simulation results for various operating conditions versus actual bench validation data. For more information on iSim:PE visit the [iSim](#) online home page.

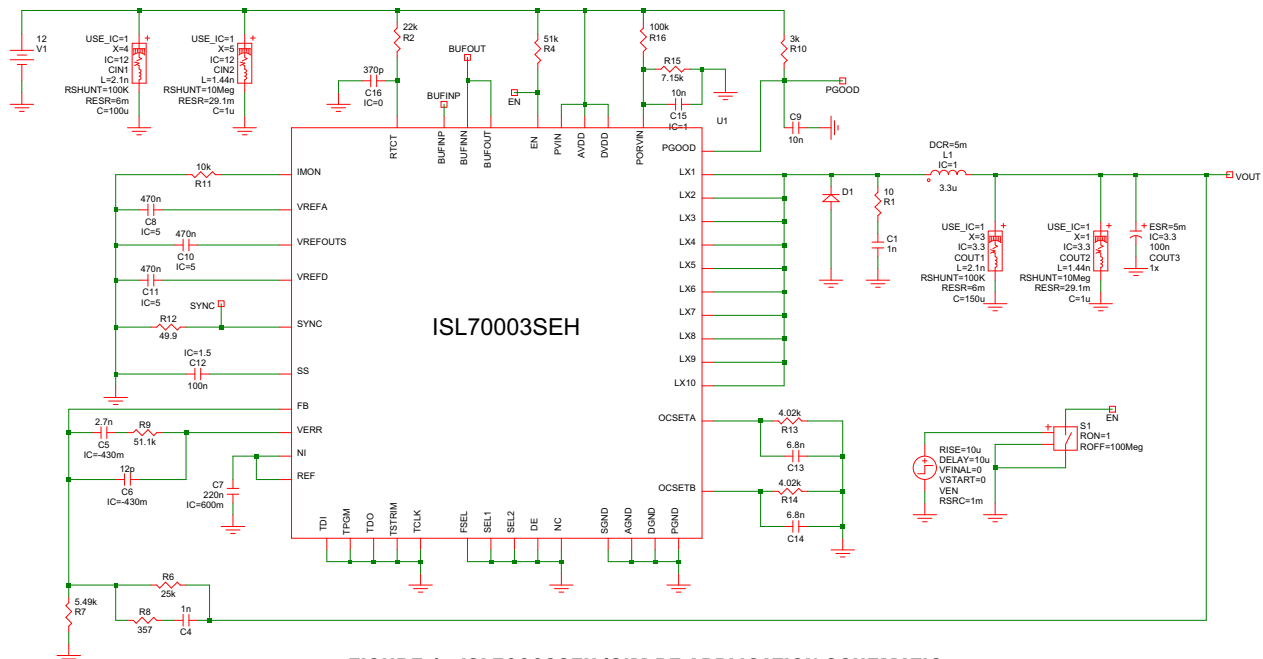

FIGURE 1. ISL70003SEH iSIM:PE APPLICATION SCHEMATIC

Simulation Performance Curves

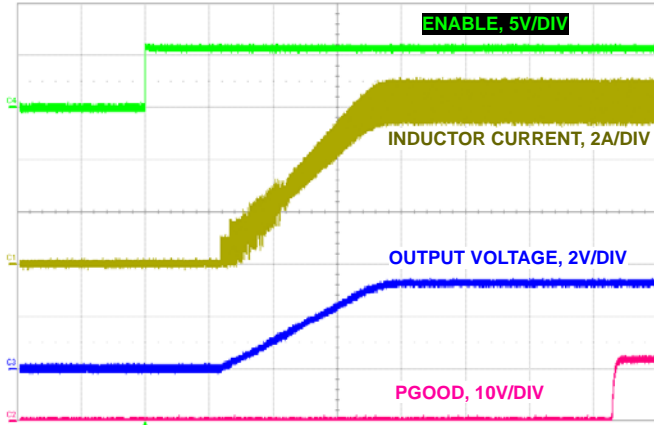

FIGURE 2. CHARACTERIZED SOFT-START WITH 6A LOAD

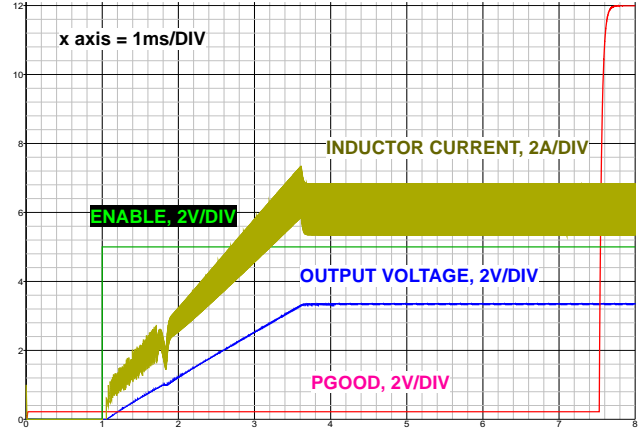

FIGURE 3. SIMULATED SOFT-START WITH 6A LOAD

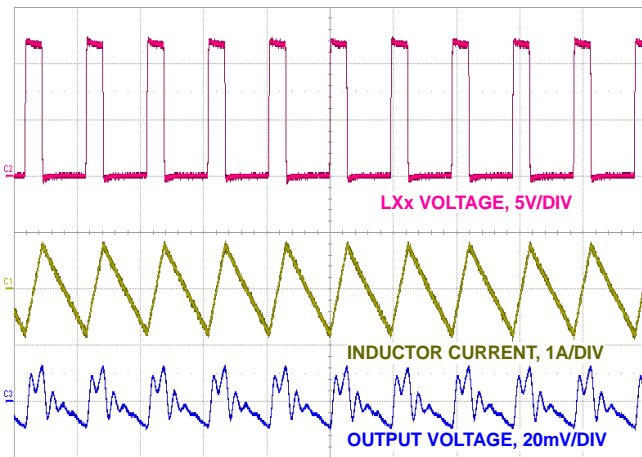

FIGURE 4. CHARACTERIZED FREQUENCY RESPONSE vs GAIN

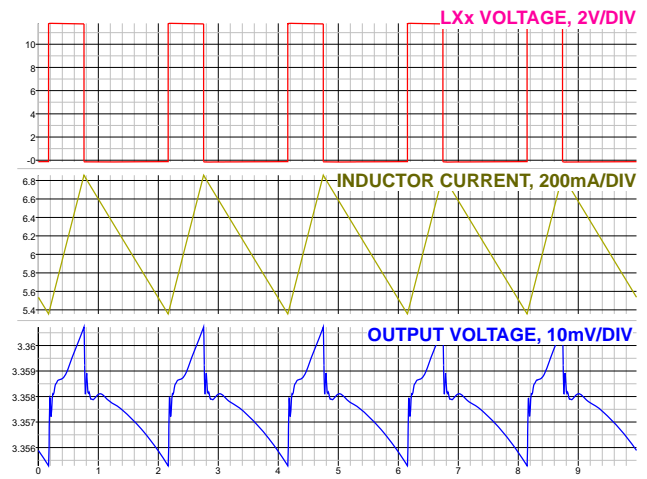

FIGURE 5. SIMULATED FREQUENCY RESPONSE vs GAIN

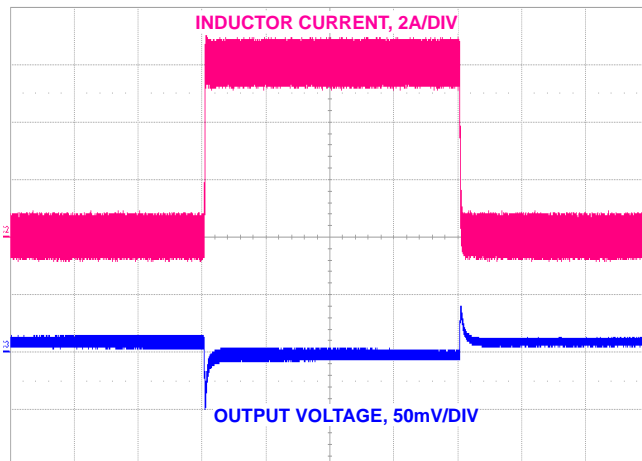

FIGURE 6. CHARACTERIZED 6A LOAD TRANSIENT RESPONSE

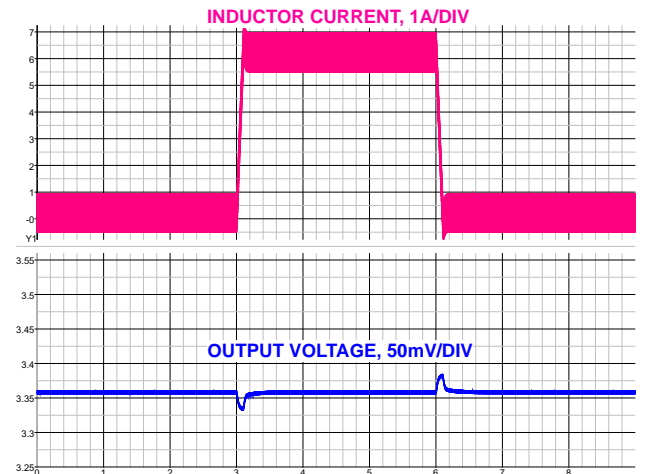

FIGURE 7. SIMULATED 6A LOAD TRANSIENT RESPONSE

Simulation Performance Curves (Continued)

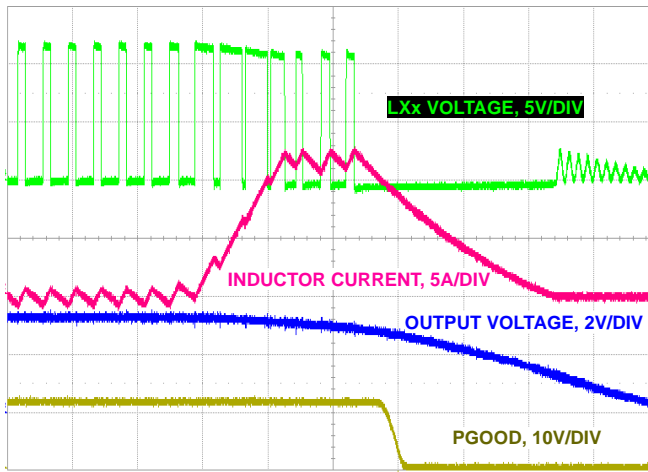

FIGURE 8. CHARACTERIZED OVERCURRENT RESPONSE

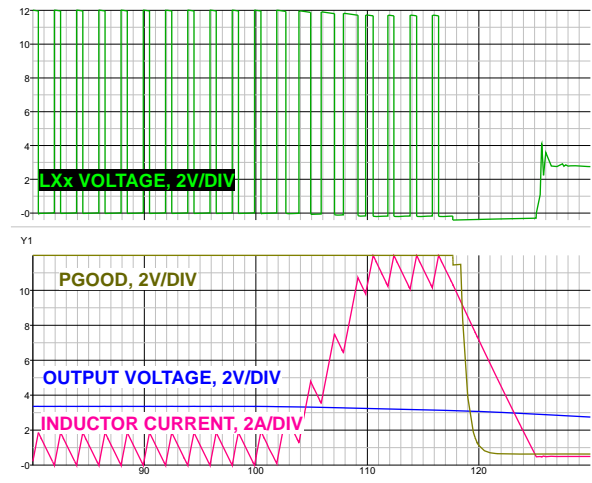

FIGURE 9. SIMULATED OVERCURRENT RESPONSE

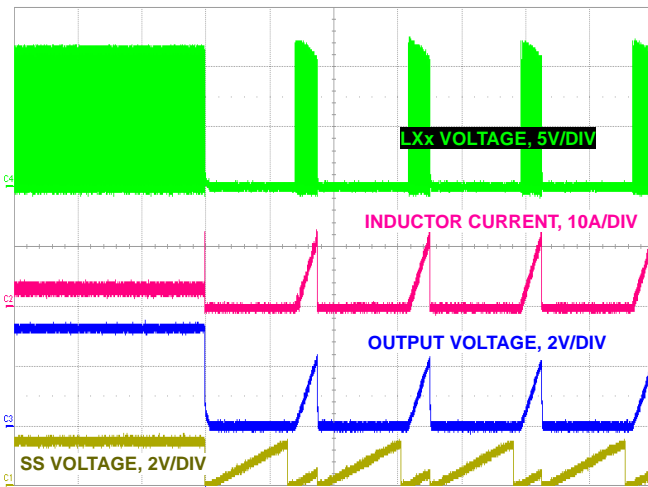

FIGURE 10. CHARACTERIZED HICCUP RESPONSE IN OCP

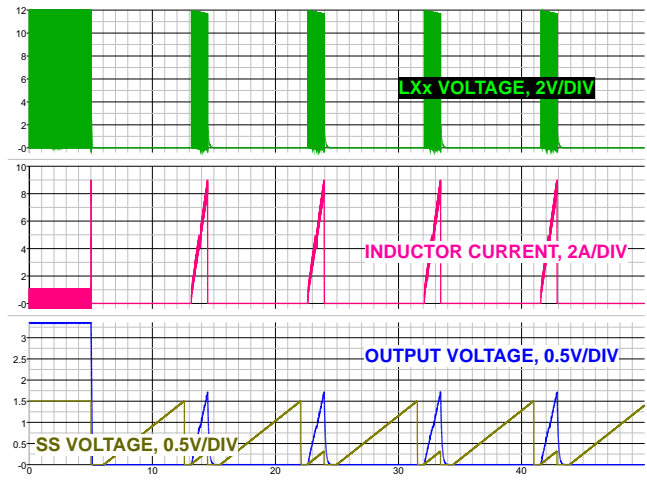

FIGURE 11. SIMULATED HICCUP RESPONSE IN OCP

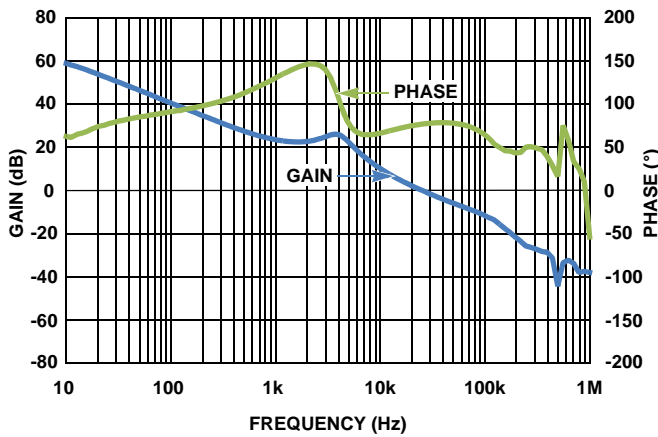

FIGURE 12. CHARACTERIZED LOOP RESPONSE

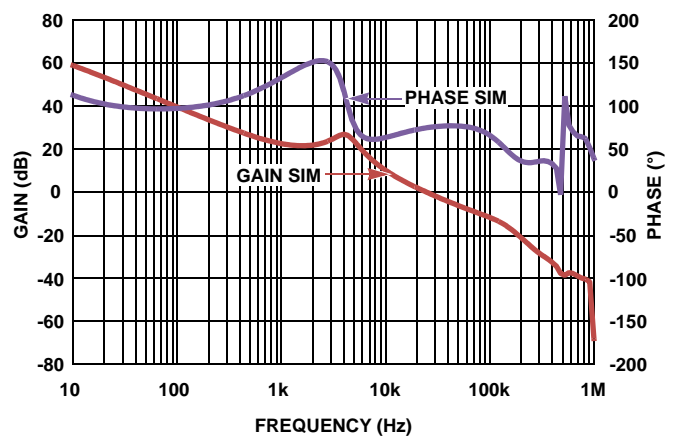

FIGURE 13. SIMULATED LOOP RESPONSE

Intersil Corporation reserves the right to make changes in circuit design, software and/or specifications at any time without notice. Accordingly, the reader is cautioned to verify that the Application Note or Technical Brief is current before proceeding.

For information regarding Intersil Corporation and its products, see www.intersil.com